

# SYNERGY TRIPLE-WIDTH SHELF - SA/TS

Hardware Bag - PHK-505

## Parts

- 2 - Center Post
- 1 - Triple-Width Shelf
- 2 - Shelf Brackets
- 1 - Spanner Post

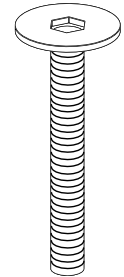
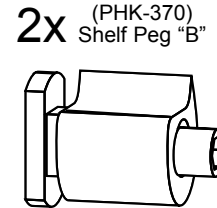
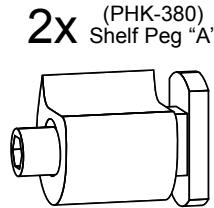
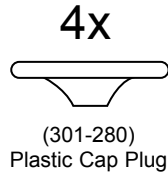
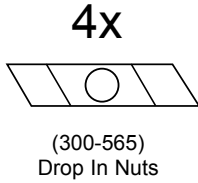
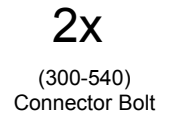
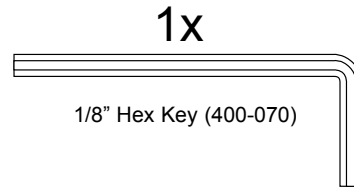
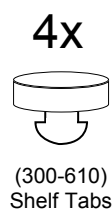
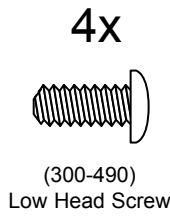
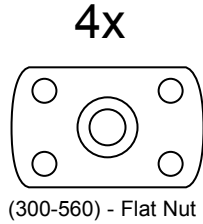

## Installing the Triple-Width Shelf to Assembled Units

Remove top connector bolts and set top aside for step 4. Then remove the 2 front and center posts.

# 1 Connect Posts to Bottom Shelf

### A. Connect Post

Install 2 short posts front and center. Square the post to the bottom shelf and screw foot with metal washer through to the extruded post. Hand tighten fully and use wrench to tighten nut onto underside of shelf.



#### WARNING:

Tighten by screwing the leveler foot NOT the post.

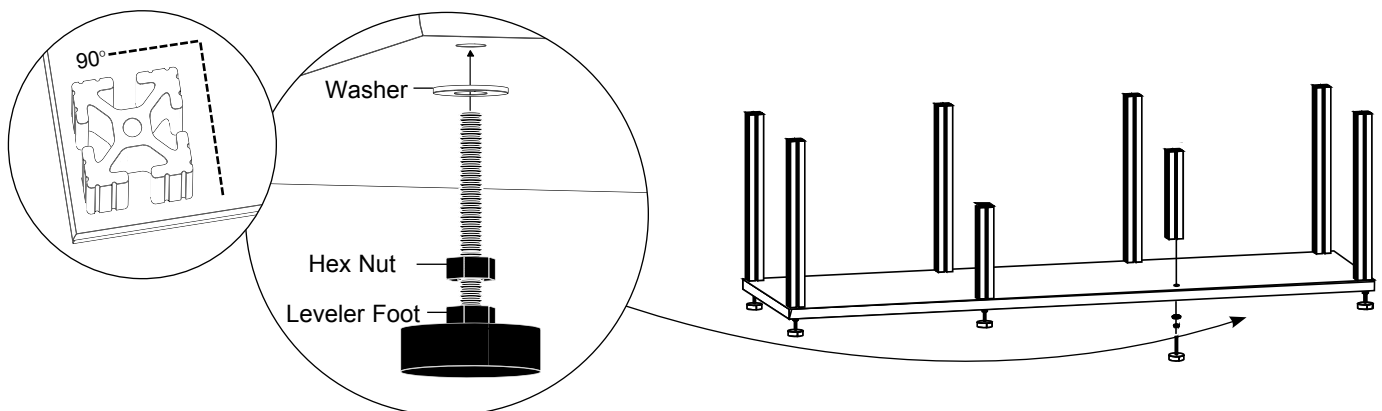

## 2 Shelf Brackets & Shelf

- A. Place the low head screws through the 2 holes of each shelf bracket and attach loosely to \*Flat Nuts.
- B. Insert 2 rubber shelf tabs through the top of each bracket.
- C. Slide the flat nuts/bracket down the post channels.
- D. Align the brackets to the top of the center posts.
- E. If installing doors, place 2 shelf pegs near top of center posts for door stops.

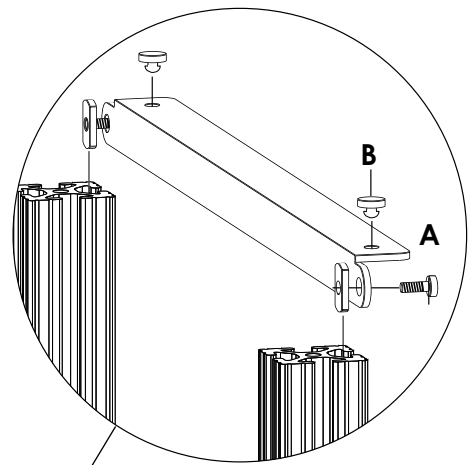

If you are installing the shelf \* to an assembled unit use the Drop-In-Nuts (300-565) in place of the Flat Nuts.

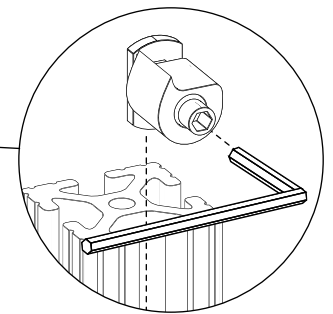
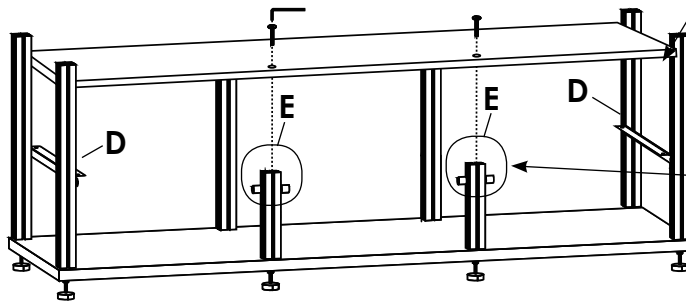

## 3 Install Spanner

- A. Disassemble cross dowel using the hex key as shown.

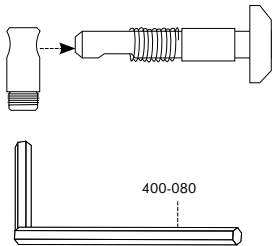

- B. Install the cross dowels into both ends of the spanner post as shown. Gently tighten the set screw in place with the hex key. (Adjust set screw to move dowel fastener in and out as needed.)

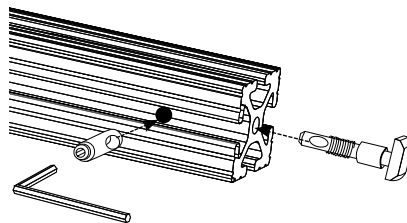

- C. Slide the spanner post into the front two riser posts. Tighten cross dowels

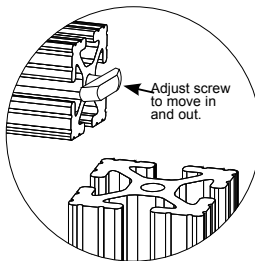
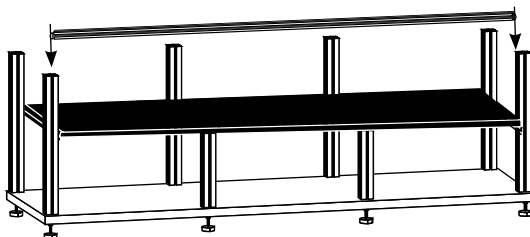

## 4 Final Assembly

Secure top with connector bolts. Use the plastic cap plugs to conceal center holes.

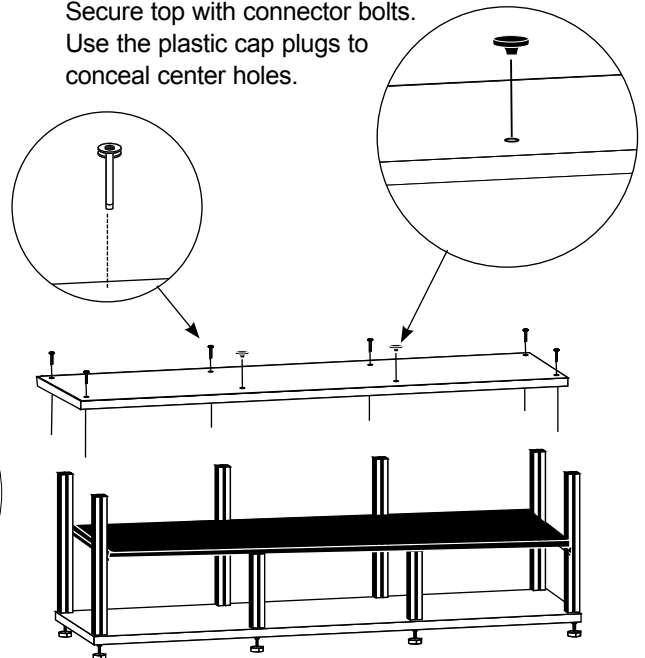

### Limited Warranty

Five full years Salamander Designs Ltd will repair or replace, at our option, any product defective in materials or craftsmanship. Salamander Designs Ltd. will not be responsible for any damage to or destruction of other equipment consequential to our equipment failure. Defective product must be given Return Authorization and is to be returned to the factory prepaid, in the original carton and packing material. Any damage incurred in a shipment not in original packaging shall be the responsibility of the owner. Warranty repairs will be returned prepaid, via UPS within the continental U.S.A. only.